

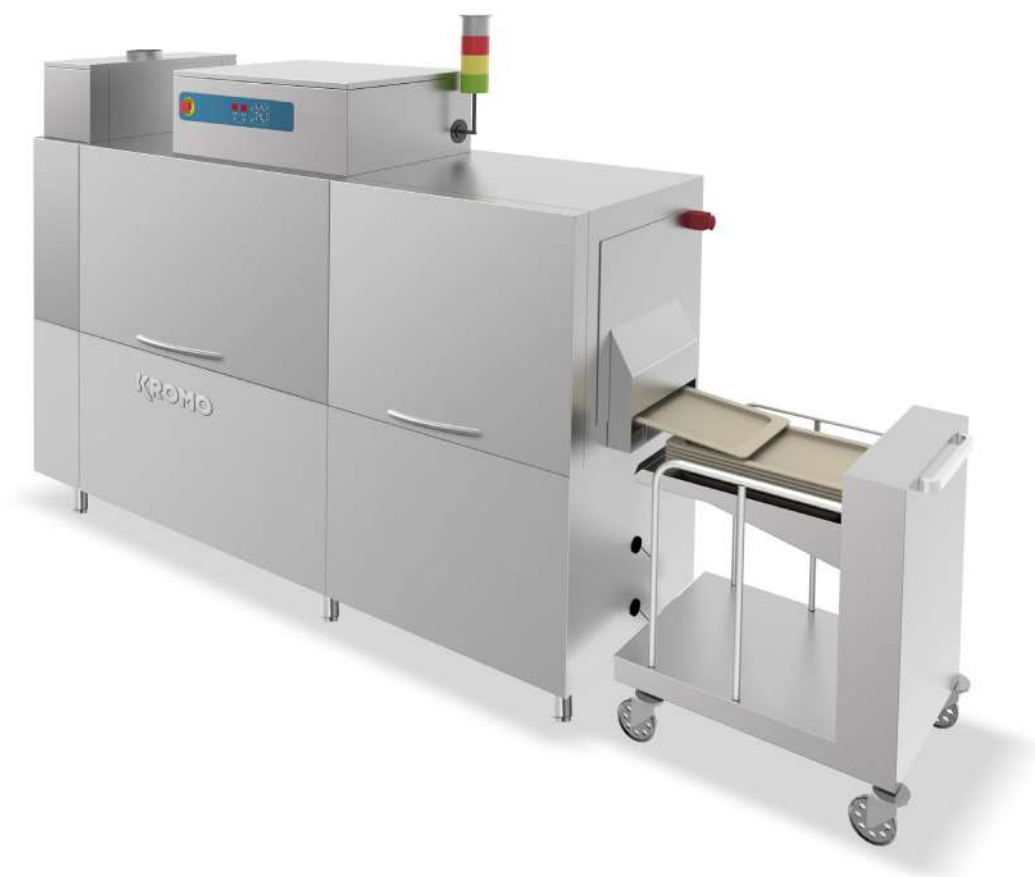

TRAY
TUNNEL TRAY WASHER
& TRANSPORTATION SYSTEMS

KROMO
YOUR SMART WASH



Le récupérateur thermique standard utilise les vapeurs produites par la machine pour préchauffer l'eau froide du réseau d'alimentation tout en garantissant une économie d'énergie immédiate. Les cordes spéciales du système d'entraînement, inclinées et divisées par zone, évitent la contami-

nation entre les modules et facilitent le séchage à froid à haute pression. Grâce aux turbosoufflantes et aux "lames d'air" sur mesure, la technologie KROMO permet d'obtenir des résultats parfaits et la réutilisation immédiate des plateaux



SELF-CLEANING

The machine's cleaning and sanitization is one of the most dreaded tasks to accomplish at the end of a day at work in the kitchen. For this reason, we have conceived a sanitization system which ensures a thorough and immediate cleaning of all machine's surfaces thanks to the special rinse arms installed on the upper wall, thus offering the perfect solution to meet maximum hygiene requirements. A dedicated sanitization product is combined with a booster pump ensuring the right water pressure: the result will be a spick and span dishwasher!

FEATURES

- Low voltage electronic control panel
- Fast coupling wash-arms, with concave self cleaning nozzles, equipped with flow adjuster
- ACID PROOF AISI 316 wash tanks, with rounded corners to guarantee a perfect hygiene
- The overflow pipe enables the full draining of the wash tanks without removal
- ACID PROOF AISI 316 stainless steel boilers, fully insulated to reduce thermal losses
- Standard heat recovery
- Double skin insulated doors, counter-balanced, equipped with anti-drop safety system
- THERMO BARRIER system for comfort in use
- CLEAN+ filters
- Built-in turbo blowers feed the air nozzles positioned both above and below the twin-cords
- Turbo-blowers. Thanks to a high pressure of the air vortex
- Trays accumulator in the absence of trolley
- Advancement system. Eases the removal of any solid residual on the tray allowing its complete rinse
- Two speeds traction system with built-in clutch. Speed adjuster on request
- Non-return valve
- Autotimer: built-in device that switches the electrical options
- HACCP: data management software on request

Model	Voltage	Capacity	Poids	Code
TK 1600	400 V 3N ~ 50 Hz 44 kW 8,4 - 13,1 m/min Cold water supply	GN 1/1 530x325x35 H	2575x805 2040/2120 H 485 kg	TK 1600

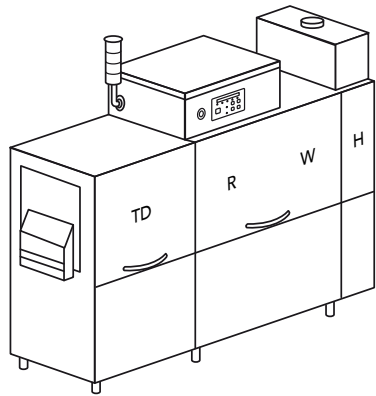

- W** Wash
- R** Rinse
- TD** Cold dryer with turbo blowers
- H** Heat recovery

OPTIONS

Model	220-240 V 3 50 Hz	380-415 V 3N 50 Hz	60 Hz	Trays Accumulator	DDE-GROUP Dispensers Kit	DOS/S Dispenser with Probe	PAP Booster Pump	DRIVE Smart drive
TK 1600	€	●	+3%	●	€	€	€	€

- Standard
- DDE-GROUP** Both detergent (with probe) and rinse aid dispensers included
- DOS/S** Only for detergent dispenser
- DRIVE** Check voltage compatibility

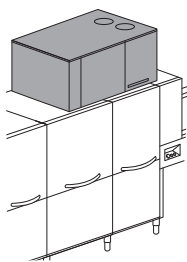

KHRP40
Heat recovery with heat pump

Model	Capacity	Poids	Code
TL 100 TROLLEY FOR TRAYS	 530x325x35 H	800x500x900 H 30 kg	TL 100

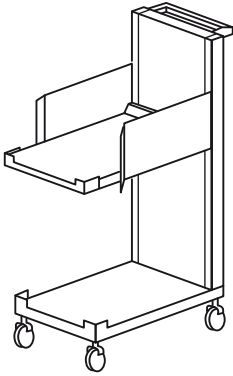

	DWI	HACCP	PI	AUTOTIMER	KHR5	KHRP40	SAN	PAP-SAN	BT
Model	Thermoacoustic insulation	HACCP supervisor	s/s Pumps	Autotimer	Heat recovery	Heat recovery with heat pump	Sanitization	Booster Pump Sanitization	Break Tank
TK 1600	€	€	€	●	●	€	€	€	€

KHR5 Heat recovery (cold water supply 8-15 °C)

DWI Insulation option for the tunnel only, dryer excluded. Recommended with the standard heat recovery KHR5 and with the KHRP30

HACCP Software and cables included

KHRP40 In alternative to standard compact heat recovery

BT Booster pump included

Division not available

Option compatibility to be confirmed by the manufacturer after verification

We recommend to install the machine in a well ventilated room, with a properly sized steam exhausting system

EAC label upon request



KROMO ALI GROUP SRL

Via Mestre, 3
31033 Castelfranco Veneto (TV)
T: +39 0423 734580
F: +39 0423 734581
kromo@kromo-ali.com

SERVICE:

T. +39 0423 734593
F: +39 0423 734592
E: service@kromo-ali.com

www.kromo-ali.com

Edition 05.2023

an Ali Group Company



The Spirit of Excellence